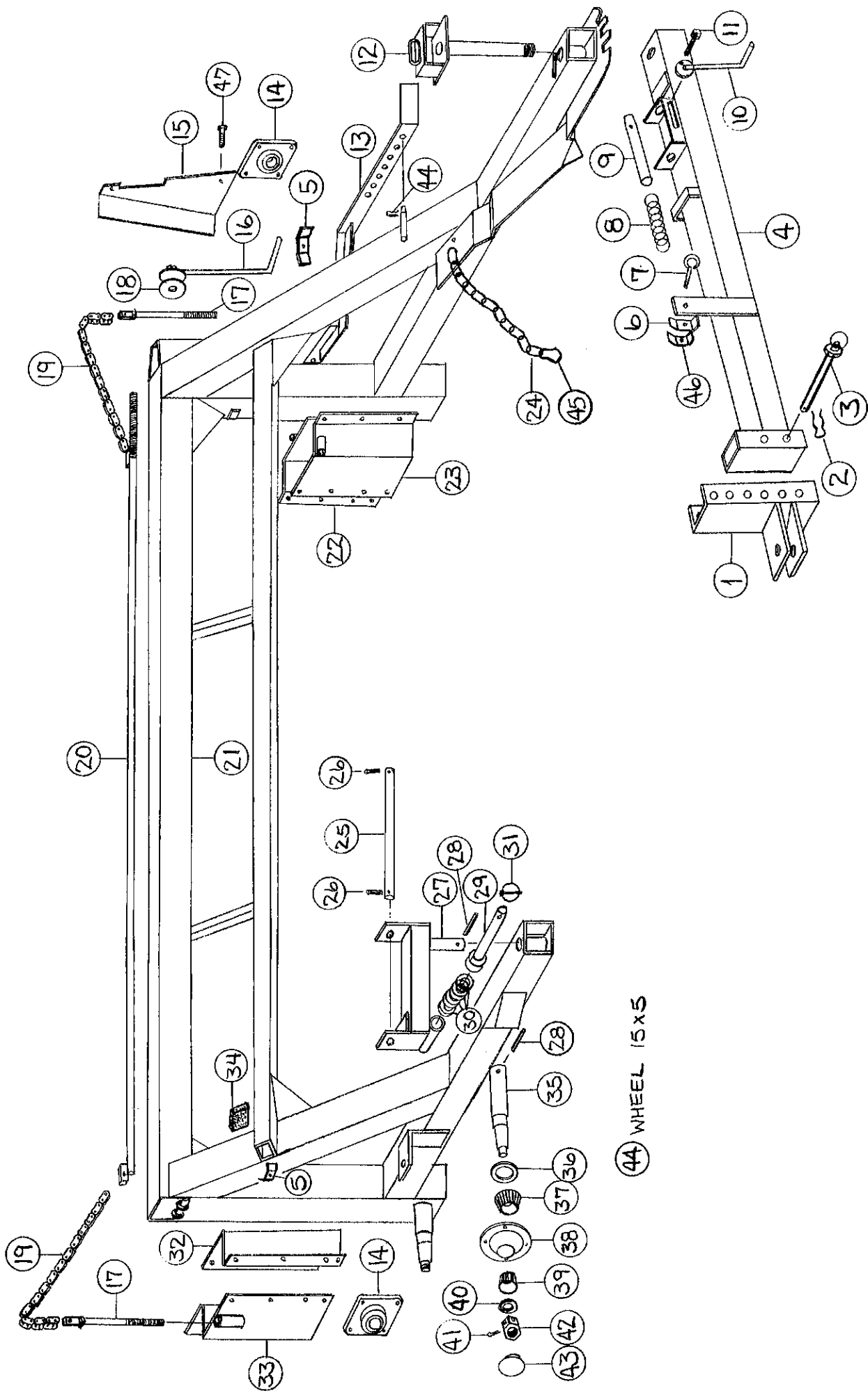

Figure 1



VIEWED FROM FRONT

**FIGURE 1
MAIN FRAME ASSEMBLY**

NO.	PART NO.	DESCRIPTION
1	BFR129	Hitch
2	ES7	Hair Pin
3	BFR5	Hitch Pin
4	T200	Pole
5	T223	Hose Clamp
6	HE42	Hose Clamp
7	BFR319	"I" Bolt
8	T201	Spring
9	T202	Pole Latch Pin
10	T203	Latch Handle
11	T245	Latch Bolt 3/8" X 3" Gr. 5
12	T204	Pole Pivot Pin
13	T205	Tine Pitch Handle
14	33SV65	Bearing
15	T206	Drive Belt Shield
16	T207	Reel Lift Crank
17	T208	Lifting Bolt
18	T209	Poly Washer
19	T210	Lifting Chain
20	T211	Lifting Shaft
21	T212	Main Frame
22	T213	Left Outer Reel Slide
23	T214	Left Inner Reel Slide
24	T215	Safety Chain
25	T216	Yoke Pin
26	3G22	Roll Pin
27	T217	Yoke
28	12V59	Roll Pin 3/8" X 2-3/4"
29	T218	Width Adjuster
30	T219	Adjustment Spacer
31	F56	Clip Pin
32	T220	Right Inner Reel Slide
33	T221	Right Outer Reel Slide
34	BFR344	Foam Insert
35	T222	Spindle
36	BFR57	Seal
37	BFR58	Inner Bearing
*	BFR59	Inner Race
38	BFR60	Hub
39	BFR62	Outer Bearing
*	BFR61	Outer Race
40	BFR63	Washer
41	BFR65	Cotter Pin
42	BFR64	Nut
43	BFR66	Hub Cap
44	BFR67	Wheel 15 X 5
45	BFR295	Snap Hook
46	23N67	Hose Clamp
47	12V66	Bolt 5/16" X 3/4"

NOTE: * (means not shown)

Figure 2

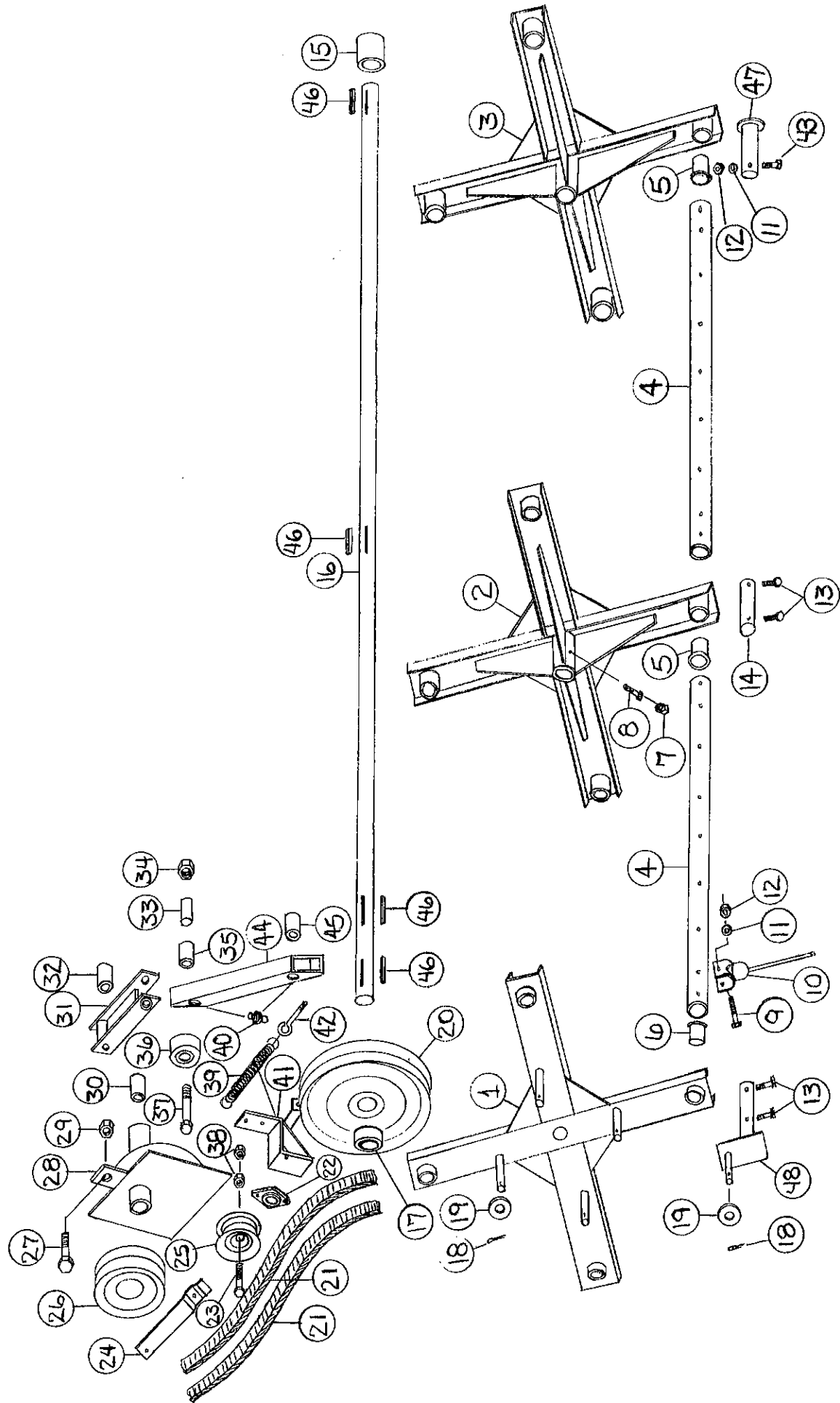

VIEWED FROM BACK

**FIGURE 2
REEL ASSEMBLY**

NO.	PART NO.	DESCRIPTION
1	T74	LH Reel Cross
2	T75	Center Reel Cross
3	T76	RH Reel Cross
4	T784	Reel Pipe
5	T78	Bronze Bushing 1-1/4" ID
6	T79	Bronze Bushing 1-1/4" ID
7	T116	Nut 5/16"
8	T115	Setscrew for Reel
9	T123	Bolt 3/8" X 2-1/4" Gr. 5
10	T82	Rubber Mounted Teeth
11	B68	Lock Washer 3/8"
12	K60	Nut 3/8"
13	T114	Bolt 3/8" X 2" Gr. 5
14	T85	Center Stub Shaft
15	T246	Spacer 3"
16	T224	Reel Shaft
17	T254	Spacer 1-1/4"
18	T72	Cotter Pin
19	T73	Washer
20	T225	Pulley
21	T226	V-Belt
22	T40	Bearing
23	17G43	Bolt 1/2" X 3-1/2"
24	T227	Drive Belt Tightener
25	K156	Pulley
26	T252	Pulley <i>w/shaft</i>
27	T62	Bolt 5/8" X 1-1/2"
28	T64	Cam Assembly
29	T60	Nut 5/8" Lock
30	T63	Bronze Bushing 1-3/8" ID
31	T59	Cam Short Arm
32	T58	Bronze Bushing 3/4" ID
33	T122	Steel Bushing
34	T60	Nut 5/8" Lock
35	T52	Bronze Bushing 3/4" ID
36	T66	Cam Roller Bearing
37	T65	Bolt 5/8" X 4"
38	9S17	Nut 1/2" Lock
39	ST36	Spring
40	T67	Long Grease Zerk
41	T228	Bearing Mount
42	ES10	"I" Bolt
43	T19	Bolt 3/8" X 2"
44	T53	Cam Long Arm
45	T52	Bronze Bushing
46	T50	Sq. Key 5/16" X 2"
47	T83	RH Stub Shaft
48	T80	LH Stub Shaft

Figure 3

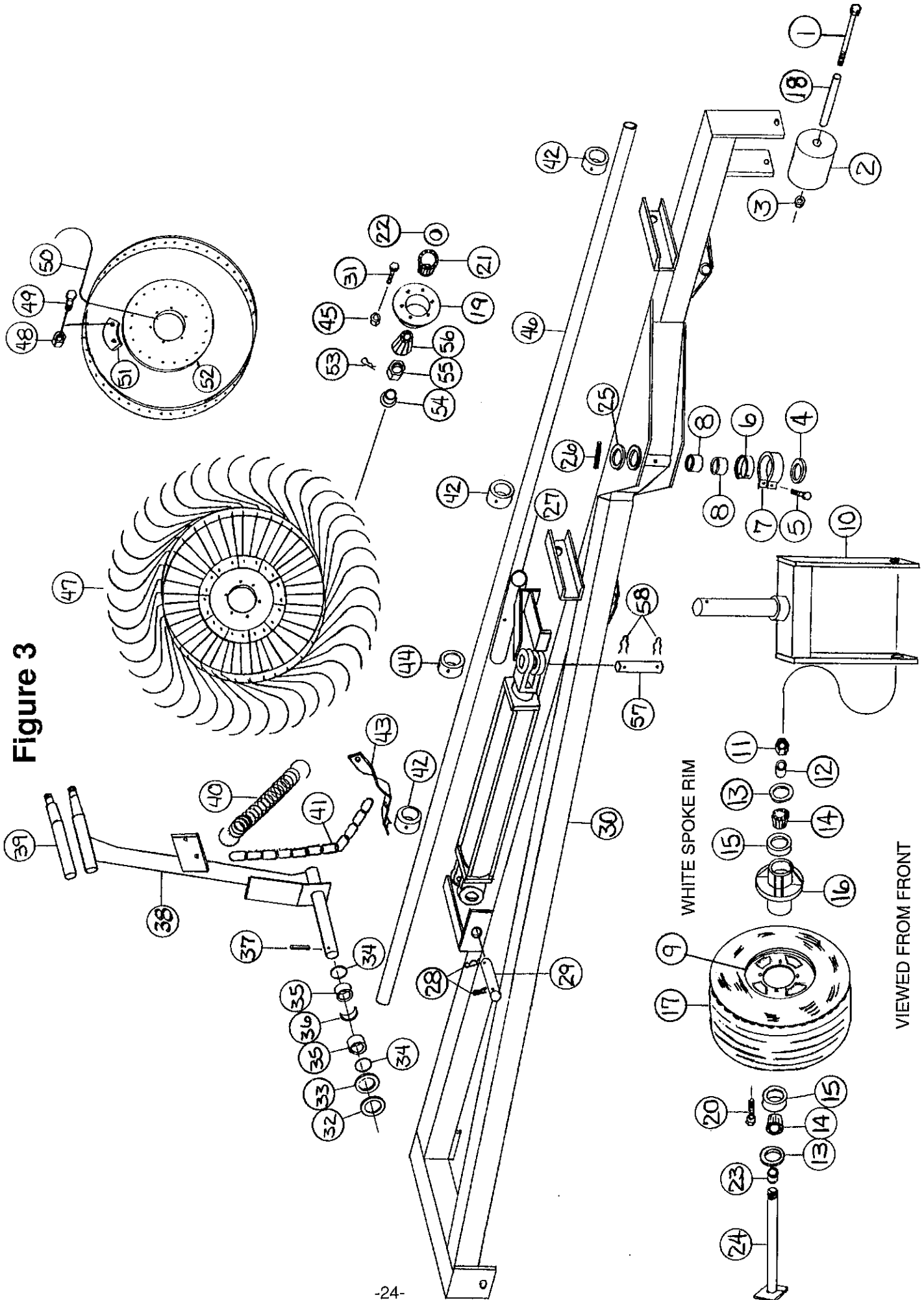

**FIGURE 3
RAKE BEAM ASSEMBLY**

NO.	PART NO.	DESCRIPTION
1	BFR224	Bolt 1/2" X 4-1/2" Gr. 5
2	BFR226	Poly Roller
3	R29	Nut 1/2"
4	BFR269	Bronze Washer
5	X26	Full Thread Bolt 3/8" X 3" Gr. 2
6	BFR267	Brake Pad
7	BFR268	Brake
8	23N17	Bronze Bushing
9	BFR280A	Wheel - Spoked
10	BFR270	Complete Fork
11	BFR271	Nylon Lock Nut 1"
12	BFR272	Spacer
13	BFR273	Seal
14	BFR274	Bearing
15	BFR275	Race
16	BFR276	Hub
17	BFR277	Tire
18	T255	Axle Roller
19	BFR32	Hub
20	BFR339	Lug Bolt
21	T164	Inner Bearing
*	T165	Inner Race
22	T163	Seal
23	BFR278	Spacer
24	BFR279	Axle Shaft
25	BFR179	Washer
26	S106	Roll Pin
27	T229	Hydraulic Lift Bracket
28	T72	Cotter Pin
29	PB13	Cylinder Pin
30	T230	Rake Beam
31	T168	10mm X 25mm Bolt
32	BFR229	Steel Washer
33	BFR221	Poly Washer
34	S99	"O" Ring
35	G16	Bushing
36	BFR230	Spacer
37	3G22	Roll Pin
38	T231	Rake Wheel Arm
39	BFR36	Rake Wheel Spindle
40	BFR138	Spring
41	BFR140	Chain
42	BFR82	Pipe Clamp
43	BFR256	Spring Bracket
44	BFR83	Pipe Clamp
45	T166	10mm Nut
46	T232	Lifting Pipe
47	BFR31	RH Rake Wheel
48	T166	10mm Nut
49	T175	10mm X 25mm Carr. Bolt
50	T176	Rake Wheel Tooth
51	T178	Rake Tooth Clip
52	T179	Rake Wheel Center
53	T169	Cotter Pin
54	T173	Hub Cap
55	T172	Nut
56	T170	Outer Bearing
*	T171	Outer Race
57	T143	Cyl. Pin
58	T144	Clip Pin

*T177
outer
wheel*

NOTE: * (means not shown)

Figure 4

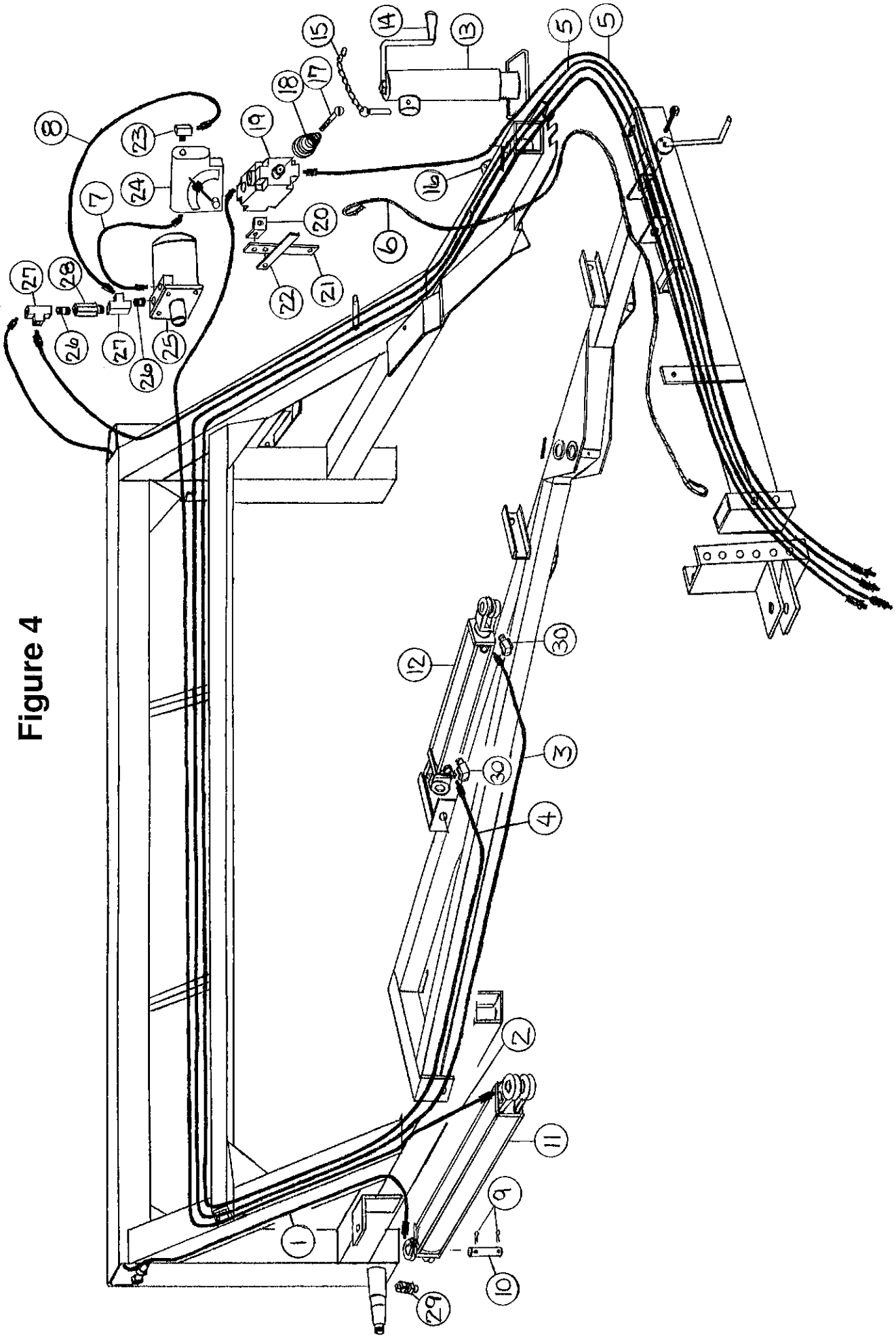

VIEWED FROM FRONT

**FIGURE 4
RAKE HYDRAULICS**

NO.	PART NO.	DESCRIPTION
1	T233	Hyd. Hose 3/8" X 168"
2	T234	Hyd. Hose 3/8" X 152"
3	T235	Hyd. Hose 3/8" X 390"
4	T236	Hyd. Hose 3/8" X 378"
5	T237	Hyd. Hose 1/2" X 192"
6	T238	Rope
7	T239	Hyd. Hose 1/2" X 19"
8	T240	Hyd. Hose 1/2" X 24"
9	T144	Clip Pin
10	T143	Cylinder Pin
11	12V116	Cylinder
12	BFR69	Hyd. Lift Cylinder
13	BFR223	Jack
14	B17B	Jack Handle
15	BFR4	Jack Pin & Chain
16	12N14	Jack Mount
17	T247	Bolt
18	T241	Spring
19	16SV133	Selector Valve
20	F92	Angle
21	T242	Valve Handle
22	T243	Valve Linkage
23	HE58	Hydraulic Elbow 1/2"
24	DF15	Speed Control Valve
25	PB64	Hydraulic Motor
26	DF7	Nipple 1/2"
27	DF8	Tee 1/2"
28	DF18	Check Valve
29	T244	Adapter Union
30	23N234	3/8" Elbow 90 Degree

Figure 5

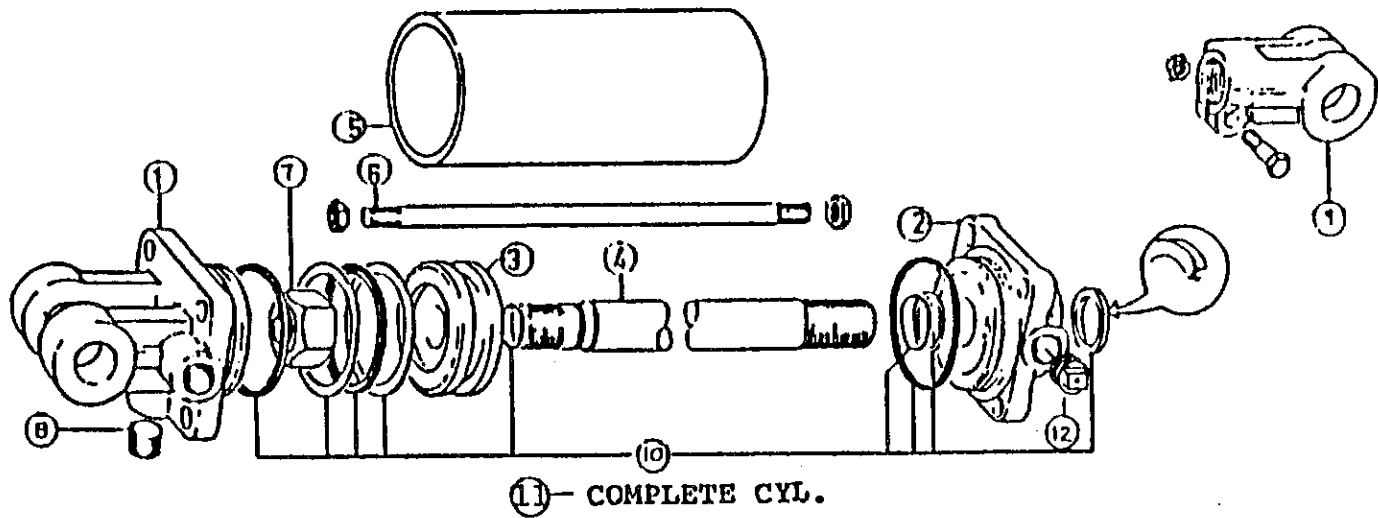

**FIGURE 5
HYDRAULIC LIFT CYLINDER**

NO.	PART NO.	DESCRIPTION
1	23N142	Clevis Cap
2	23N143	Rod Cap
3	23N144	Piston
4	T184	Rod
5	BFR68	Cyl. Tube
6	T186	Tie Rod
7	23N148	Piston Nut
8	23N149	Plug
9	23N150	Rod Clevis
10	23N151	Seal Kit
11	BFR69	Complete Cylinder
12	BFR70	Vent Plug

Figure 6

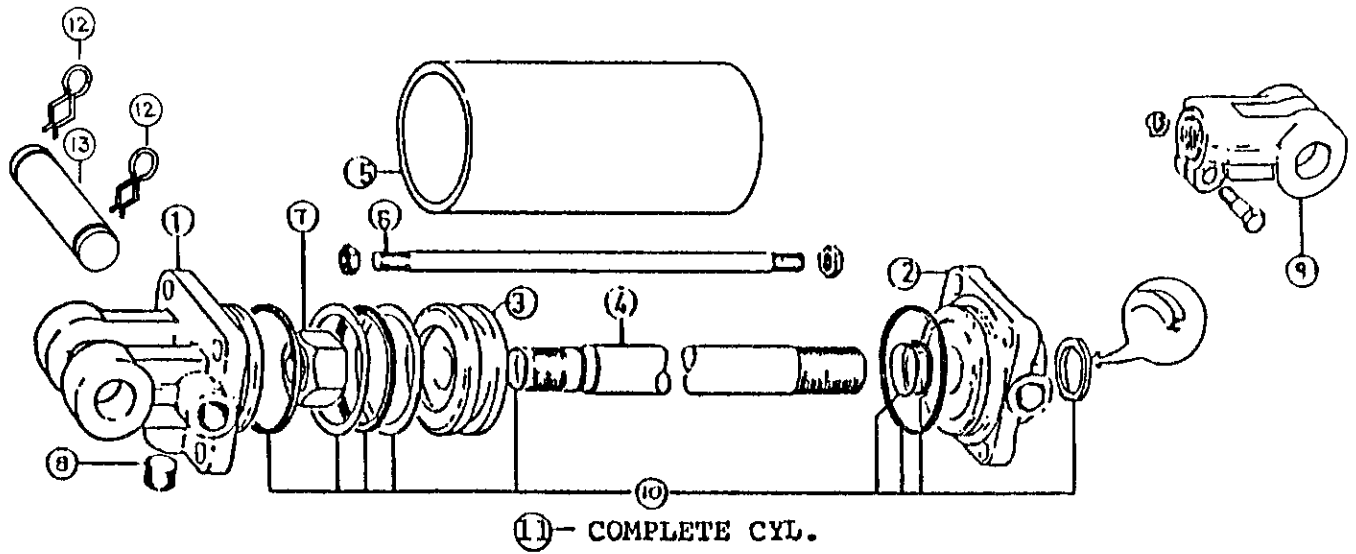

**FIGURE 6
HYDRAULIC OPENING CYLINDER**

NO.	PART NO.	DESCRIPTION
1	23N142	Clevis Cap
2	23N143	Rod Cap
3	23N144	Piston
4	23N145	Rod
5	23N146	Cyl. Tube
6	23N147	Tie Rod
7	23N148	Piston Nut
8	23N149	Plug
9	23N150	Rod Clevis
10	23N151	Seal Kit
11	12V116	Complete Cylinder
12	T144	Clip Pin
13	T143	Hyd. Cyl. Pin

Figure 7

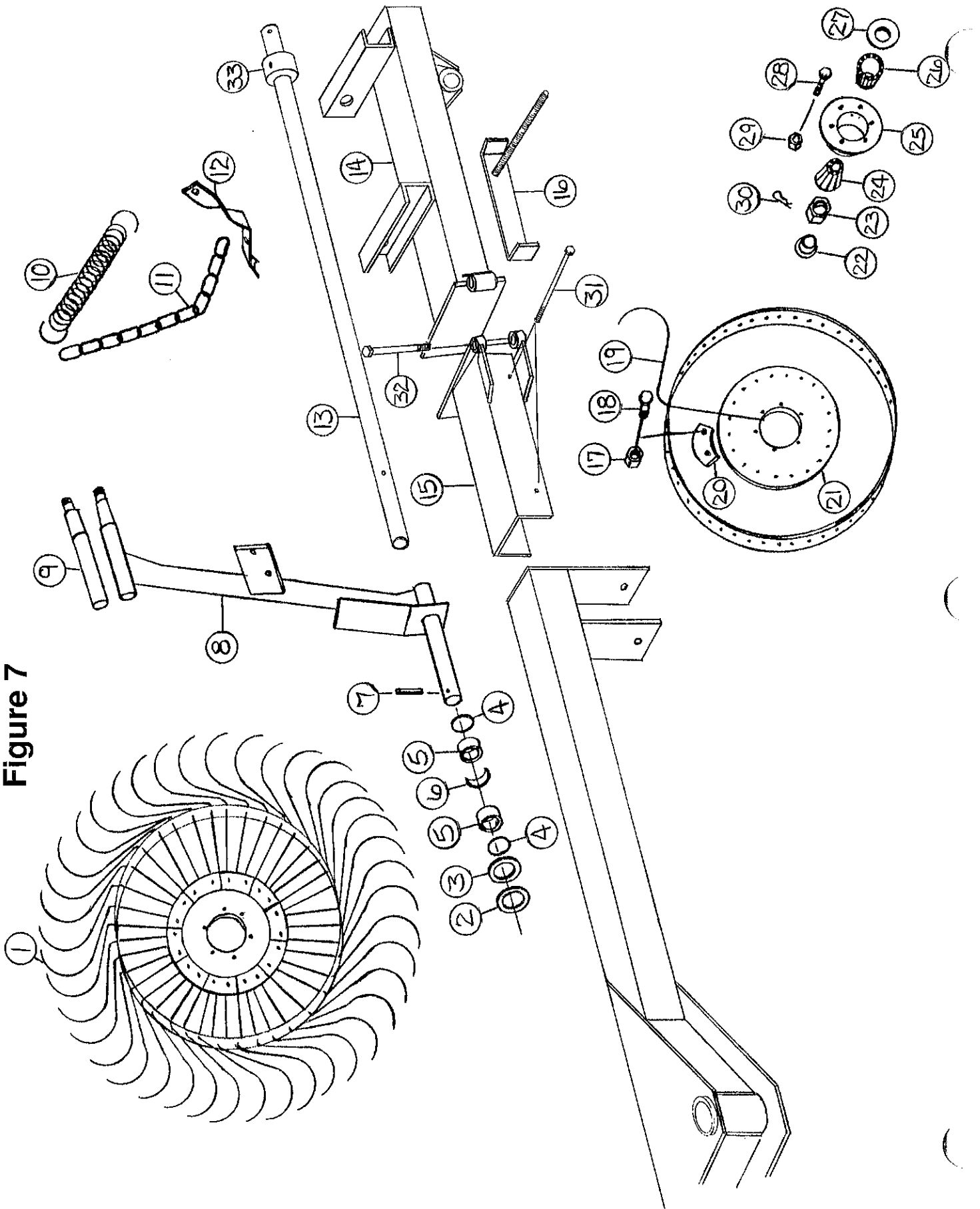

FIGURE 7
OPTIONAL FOURTH WHEEL ASSEMBLY

NO.	PART NO.	DESCRIPTION
1	BFR31	RH Rake Wheel
2	BFR229	Steel Washer
3	BFR221	Poly Washer
4	S99	"O" Ring
5	G16	Bushing
6	BFR230	Spacer
7	3G22	Roll Pin
8	T231	Rake Wheel Arm
9	BFR36	Rake Wheel Spindle
10	BFR138	Spring
11	BFR140	Chain
12	BFR256	Spring Bracket
13	T248	Lifting Pipe Clamp
14	T251	Rake Beam Extension
15	T249	Rake Beam Extension Bracket
16	T250	Latch
17	T166	10mm Nut
18	T175	10mm X 25mm Carr. Bolt
19	T176	Rake Wheel Tooth
20	T178	Rake Tooth Clip
21	T179	Rake Wheel Center
22	T173	Hub Cap
23	T172	Nut
24	T170	Outer Bearing
*	T171	Outer Race
25	BFR32	Hub
26	T164	Inner Bearing
*	T165	Inner Race
27	T163	Seal
28	T168	10mm X 25mm Bolt
29	T166	10mm Nut
30	T169	Cotter Pin
31	T253	3/8" X 4" Bolt Gr. 5
32	RG174	5/8" X 5" Bolt Gr. 5
33	BFR82	Pipe Clamp

NOTE: * (means not shown)

